



U.S. Army Financial Management School



Financial Management Update

***CSM Jeffrey C. Green
Regimental / School CSM***

***COL T. A. CLAY
Commandant / Chief of the Corps***



AGENDA



- **FM Vision**
- **FM “Game Changers”**
- **Personnel & Capabilities**
- **Organizational Structure**
- **Operational Assessment**
- **FM Contingency Operations**
- **Training**



Finance Corps Vision



OUR VISION

We are a world class community committed to providing quality and flexible Financial Management support to Army, joint, and multi-national forces across the full range of military operations

OUR FOCUS

Provide support to contingency operations with modular units and cells that leverage technology to optimize financial management capabilities.

OUR VALUES

Patriotism
Integrity  Competence
Service

U.S. Army  Finance Corps

OUR VISION

We are a world class organization committed to providing quality support to America's armed forces in peace, war, and operations other than war.

OUR FOCUS

Provide support to joint and multinational forces with biliorable units that leverage technology to optimize financial capabilities now and into the 21st century.

OUR VALUES

Integrity  Competence
Service

TO SUPPORT AND SERVE



FM “Game Changers”

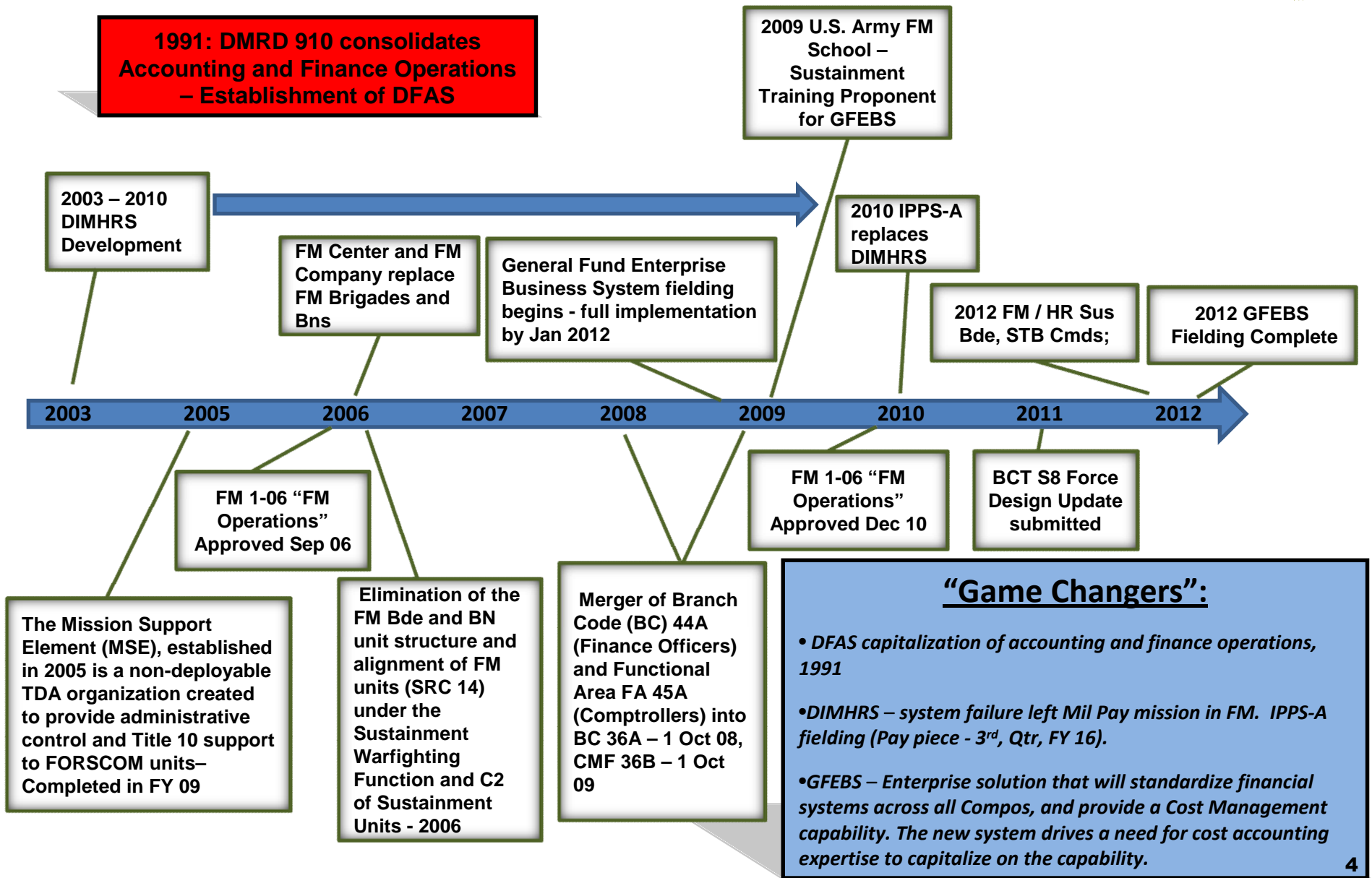



FM Core Capabilities



The Multi-Functional Financial Management Leader

**RESOURCE MANAGEMENT
OPERATIONS**

**FINANCE
OPERATIONS**

**FM Merger
BC 36**

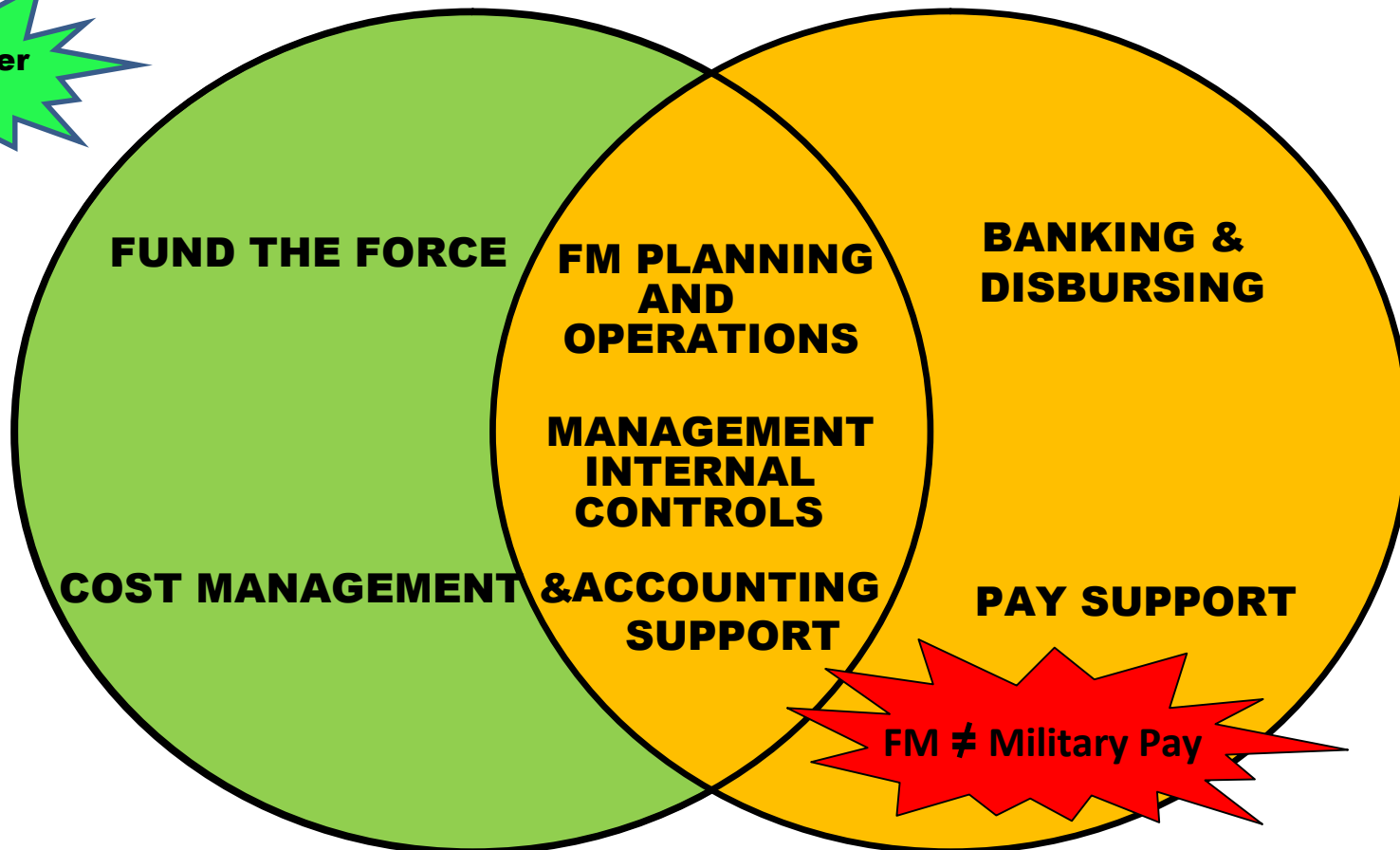

FM ≠ Military Pay



FM Doctrine



Revised FM 1-06

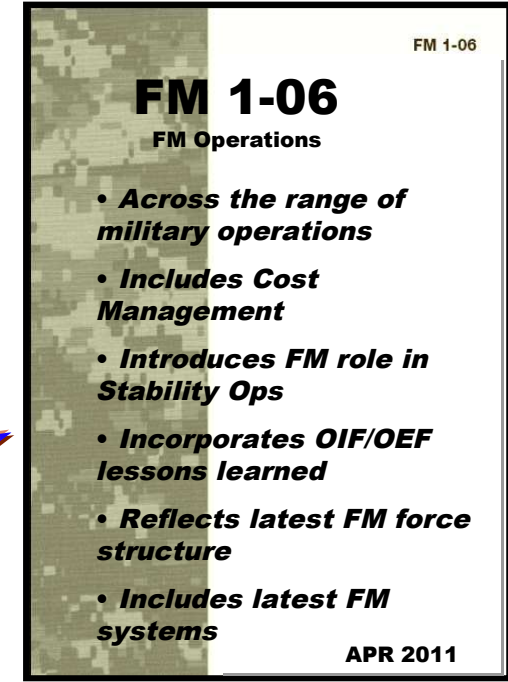

FM Doctrinal Transformation

FM split between RM and FO

Not aligned with new doctrine

Existing Force Structure



Approved Jan 11



THE FISCAL TRIAD

LEGALLY- BINDING PROCESS THAT GOVERNS THE PROCUREMENT PROCESS



CONTINGENCY CONTRACTING

CONTRACTS FOR GOODS AND SERVICES / CLOSES OUT CONTRACTS

COMMANDER

GENERATES REQUIREMENTS / FOCAL POINT OF SUPPORT

FM Separation of Duties

FINANCIAL MANAGEMENT

(Resource Management)

ACQUIRES AND CERTIFIES PUBLIC FUNDS

FINANCIAL MANAGEMENT

(Finance Operations)

DISBURSES AND ACCOUNTS FOR PUBLIC FUNDS

To Support and Serve 7



FINANCIAL MANAGEMENT



AC - OFFICERS/ENLISTED

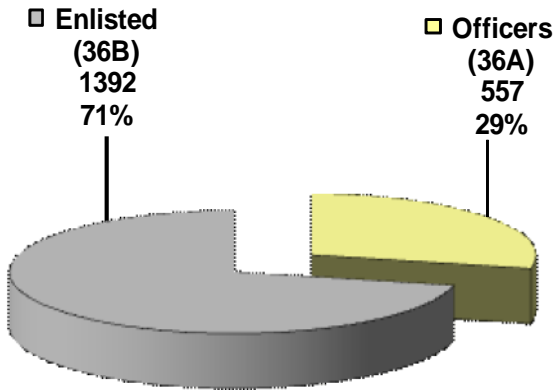

ALL COMPONENTS

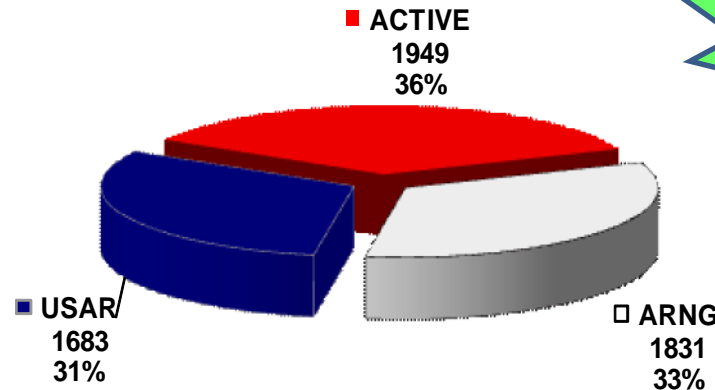

64% of Structure in the RC

68% of Structure: MTOE

Latest Approved FY 12 AUTHORIZATIONS				
AOC / MOS	ACTIVE	ARNG	USAR	TOTALS
Officers (36A)	557	367	388	1312
Enlisted (36B)	1392	1464	1295	4151
TOTALS	1949	1831	1683	5463

COMPO	MTOE	TDA	Total
AC	1577	372	1949
ARNG	1124	707	1831
USAR	1030	653	1683
Total	3731	1732	5463

SOURCE: FMSWEB

~ 11,500 Career Program 11 (Comptroller) Civilians

1/2 of 1% of the Army Structure



FM Transformation

Impact of Army Transformation (SRC 14)

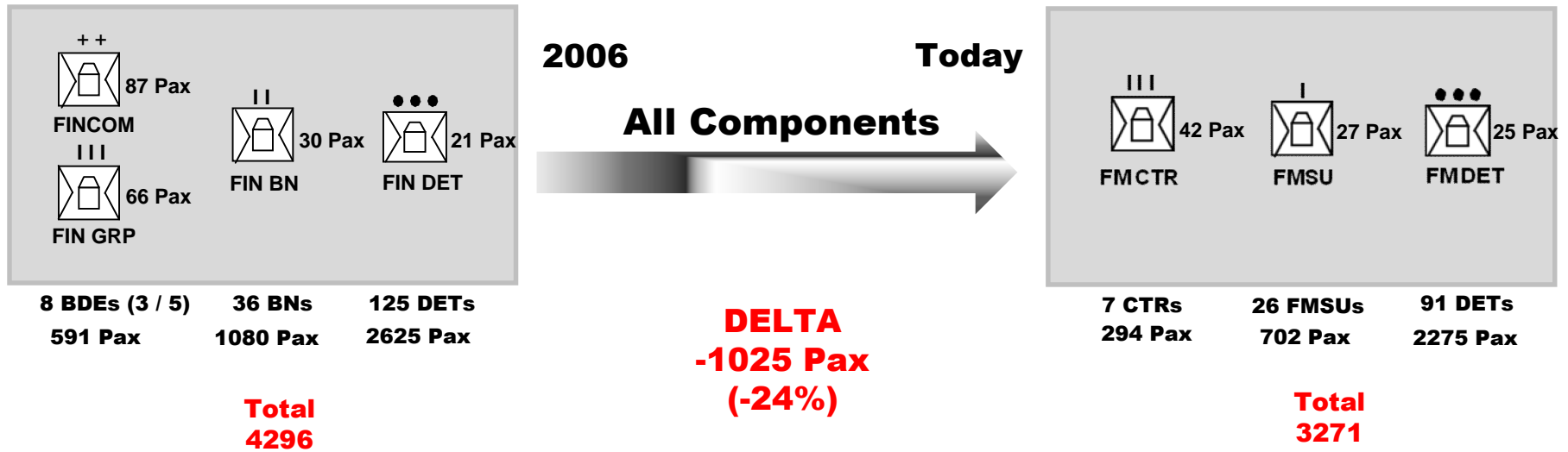

Active Component



36% Reduction of AC FM Force Since 2006

TAA 12-17 60% of Requirements

TAA 14-18 1 AC FMC (-42)



Financial Management Operational Force Assessment



- **FM Branch: ~1/2 of 1% of Army Structure (All COMPOs)**
- **64% of FM structure in the RC – COMPOs 2 (33%) & COMPO 3 (31%)**
- **FM Branch: Short LTCs (105 of 132 OH); Special authority granted for branch transfer at LTC level**
- **Large population of branch details & transfers come into FM at CPT level**
- **FM: Sustainment Warfighting Function; SRC 14 under mission command of sustainment commands**



Financial Management Operational Areas of Concern



- **FM Community: Significant bill payer ISO of Army Transformation**
 - **36% AC Force Structure Reduction since 2006**
 - **24% Force Structure Reduction all COMPOs**
 - **FM Branch: ~1/2 of 1% of Army Structure (All COMPOs)**

- **FM Branch: 2008 Merger of Basic Branch (Finance) and Functional Area (Resource Management)**
 - **Finance – pyramid structure**
 - **Resource Management (RM) - high level of experience and maturity (higher grade structure)**
 - **Results – FM Branch Merger resulted in an atypical structure (not a pyramid)**

- **Army “Fiscal Triad” – FM (RM, Contracting, and Finance)**
 - **Contracting growing & FM decreasing**
 - **Existing capability gaps (accounting, cost management, & military pay - unresourced)**

- **SECARMY-Directed: Optimization of Army Financial Management - memo, dtd 11 Sep 12**
 - **Conduct review of Army Financial Management processes, procedures, policies, organization constructs and workforce composition**
 - **Reconcile Grade Plate review with Optimization of Army FM directive**
 - **AAA Audit: FM Training; Structure & Alignment; Relevance of work / mission at H/S compared to deployment environment**

- **FM Branch: Is FM more “Special Branch-Like” based on its mission and structure?**



Financial Management Contingency Operations (Doctrinal Perspective)

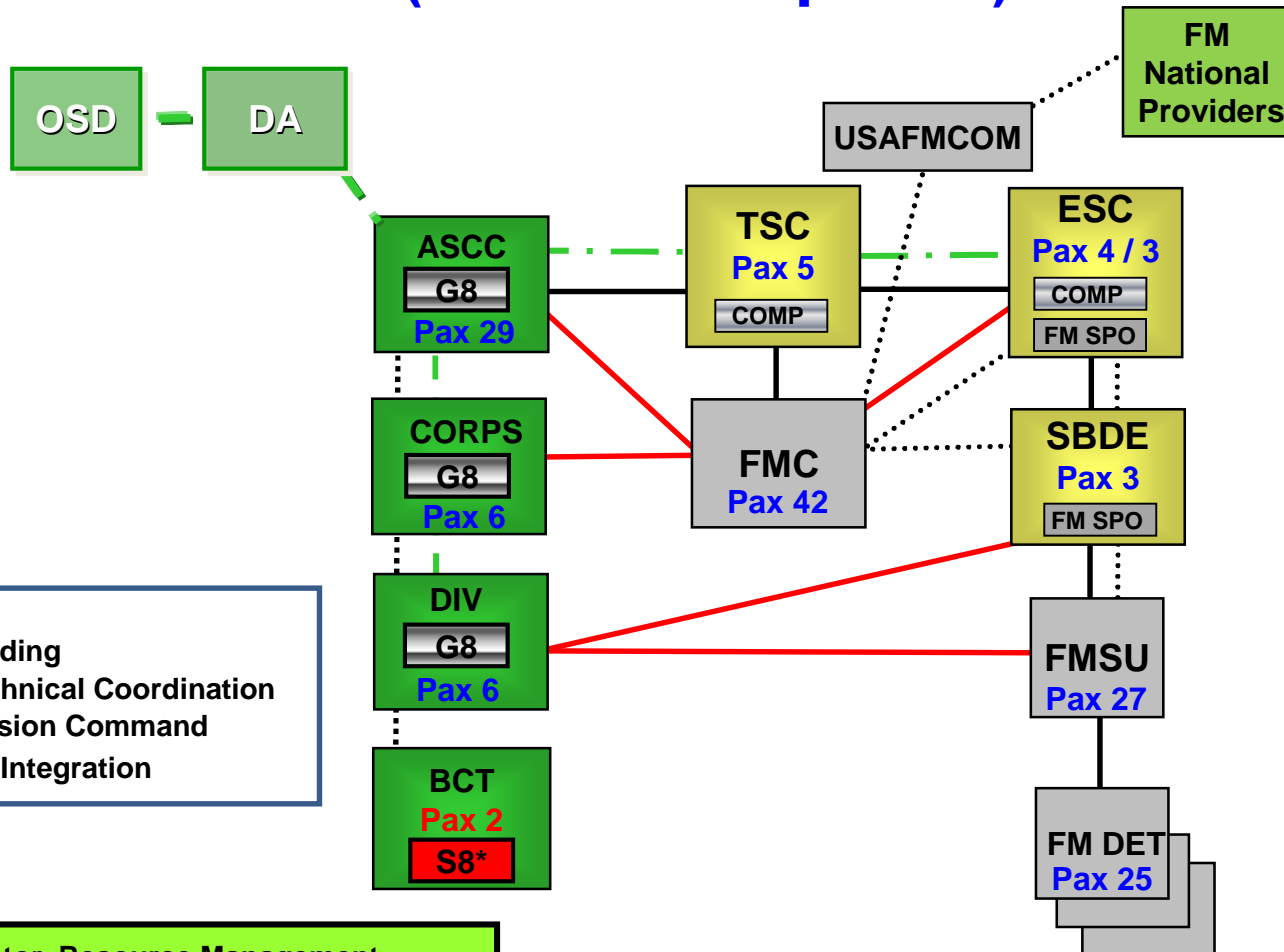

- Funding
 Technical Coordination
 — Mission Command
 — FM Integration

G8/FM = Director, Resource Management
FMC = Financial Management Center
FMSU = Financial Management Support Unit
FM DET = Financial Management Detachment
FM SPO = Financial Management SPO
COMP = Comptroller

Technical Coordination
 Technical coordination relates to the recommendations and advice to commanders and staffs regarding the employment, integration, and missioning of FM forces for the accomplishment of assigned missions.

*** TAA 14.1 (BCT Redesign)**



ARMY LEARNING MODEL (ALM) Overview



- **ALM** is continuous adaptive learning model that instills 21st century Soldier competencies through a learner-centric 2015 learning environment, supported by an adaptive development and delivery infrastructure that enables career-long learning and sustained adaptation.

Continuous Adaptive Learning Model Elements

- ✓ Identifies 21st century Soldier competencies
- ✓ Learner-centric 2015 learning environment
- ✓ Career span framework
- ✓ Adaptive development and delivery infrastructure

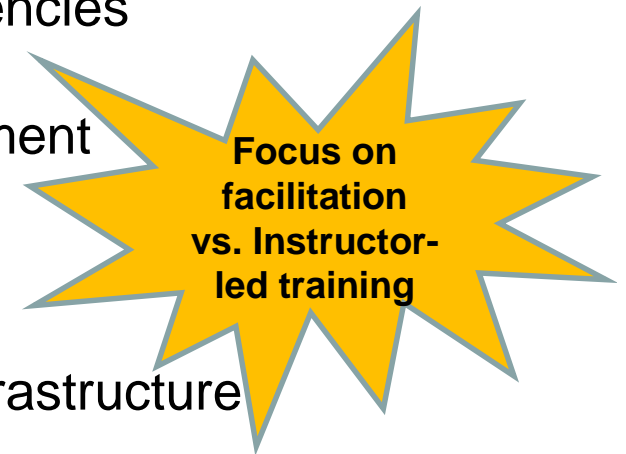

Holistic review of FM initial military training, professional military education and functional courses



General Fund Enterprise Business System

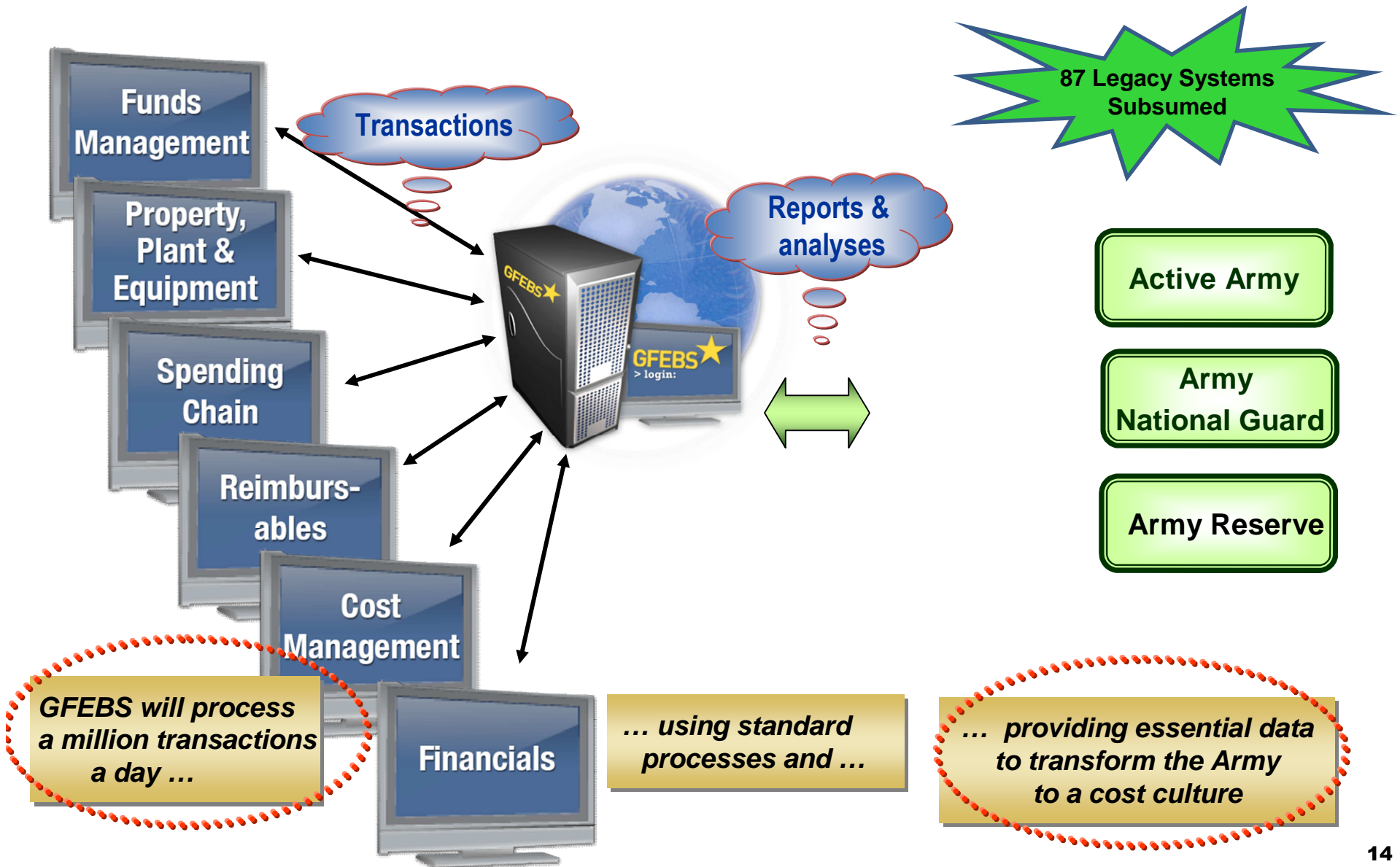



GFEBs Sustainment Training



2nd Qtr, FY 13

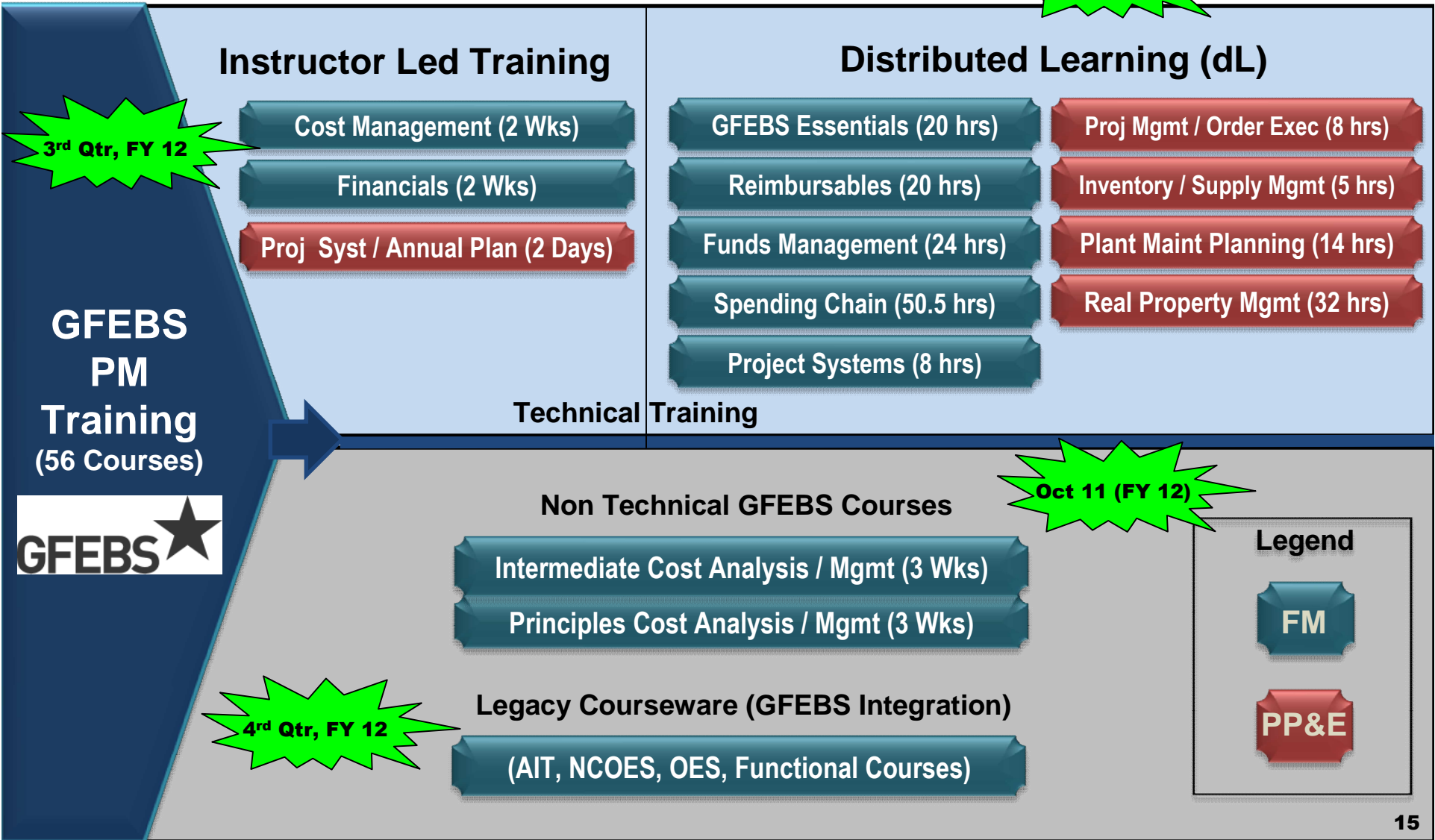



Army Financial Management



A ready and balanced force capable of executing Decisive FM Operations

- *Through superbly trained, educated, adaptive and agile Military & Civilian FM Sustainment Warriors*
- *Enabled with state of the art FM and MC systems*
- *Assist CDRs at all levels with the coordinated application of fiscal and economic power in support of national and military objectives*

OUR VALUES

Patriotism



Integrity

Competence

Service